

SN75ALS170, SN75ALS170A TRIPLE DIFFERENTIAL BUS TRANSCEIVER

SLLS055D – AUGUST 1987 – REVISED SEPTEMBER 1995

- Three Bidirectional Transceivers
- Driver Meets or Exceeds ANSI Standard EIA/TIA-422-B and RS-485 and ITU Recommendation V.11
- Two Skew Limits Available
- Designed to Operate Up to 20 Million Data Transfers per Second (FAST-20 SCSI)
- High-Speed Advanced Low-Power Schottky Circuitry
- Designed for Multipoint Transmission on Long Bus Lines in Noisy Environments
- Wide Positive and Negative Input/Output Bus Voltage Ranges
- Driver Output Capacity . . . ± 60 mA
- Thermal Shutdown Protection
- Driver Positive- and Negative-Current Limiting
- Receiver Input Impedances . . . 12 k Ω Min
- Receiver Input Sensitivity . . . ± 300 mV Max
- Receiver Input Hysteresis . . . 60 mV Typ
- Operate From a Single 5-V Supply
- Glitch-Free Power-Up and Power-Down Protection
- Feature Independent Direction Controls for Each Channel

DW PACKAGE
(TOP VIEW)

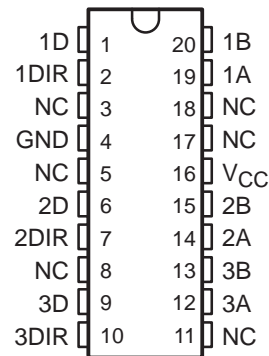

NC – No internal connection

J PACKAGE
(TOP VIEW)

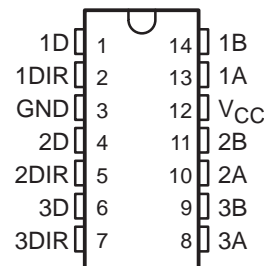

description

The SN75ALS170 and SN75ALS170A triple differential bus transceivers are monolithic integrated circuits designed for bidirectional data communication on multipoint bus transmission lines. It is designed for balanced transmission lines and the driver meets ANSI Standards EIA/TIA-422-B and RS-485 and both the driver and receiver meet ITU Recommendation V.11. The SN75ALS170A is designed for FAST-20 SCSI and can transmit or receive data pulses as short as 30 ns with a maximum skew of 5 ns.

The SN75ALS170 and SN75ALS170A operate from a single 5-V power supply. The drivers and receivers have active-high and active-low enables, respectively, which are internally connected together to function as a direction control. The driver differential outputs and the receiver differential inputs are connected internally to form differential input/output (I/O) bus ports that are designed to offer minimum loading to the bus when the driver is disabled or $V_{CC} = 0$. These ports feature wide positive and negative common-mode voltage ranges making the device suitable for party-line applications.

The SN75ALS170 and the SN75ALS170A are characterized for operation from 0°C to 70°C.

AVAILABLE OPTIONS

SKEW LIMIT	PART NUMBER	
10 ns	SN75ALS170DW	SN75ALS170J
5 ns	SN75ALS170ADW	



Please be aware that an important notice concerning availability, standard warranty, and use in critical applications of Texas Instruments semiconductor products and disclaimers thereto appears at the end of this data sheet.

PRODUCTION DATA information is current as of publication date. Products conform to specifications per the terms of Texas Instruments standard warranty. Production processing does not necessarily include testing of all parameters.

 **TEXAS
INSTRUMENTS**

POST OFFICE BOX 655303 • DALLAS, TEXAS 75265

Copyright © 1995, Texas Instruments Incorporated

SN75ALS170, SN75ALS170A TRIPLE DIFFERENTIAL BUS TRANSCEIVER

SLLS055D – AUGUST 1987 – REVISED SEPTEMBER 1995

Function Tables

EACH DRIVER

INPUT D	DIR	OUTPUTS	
		A	B
H	H	H	L
L	H	L	H
X	L	Z	Z

EACH RECEIVER

DIFFERENTIAL INPUTS A – B	DIR	OUTPUT R
$V_{ID} \geq 0.3 V$	L	H
$-0.3 V < V_{ID} < 0.3 V$	L	?
$V_{ID} \leq -0.3 V$	L	L
X	H	Z
Open	L	H

H = high level, L = low level, ? = indeterminate,
X = irrelevant, Z = high impedance (off)

logic symbol†

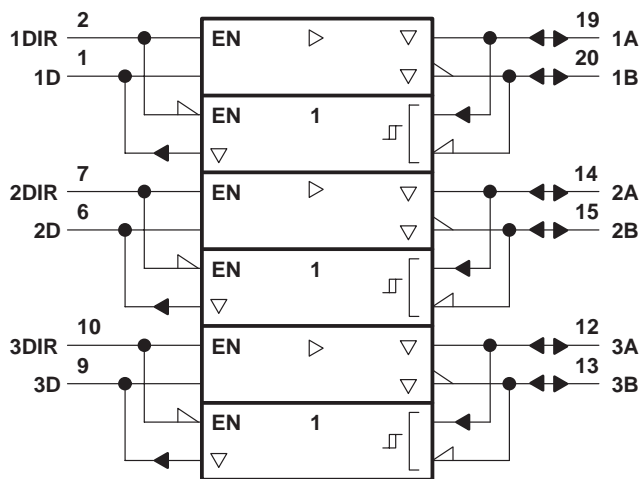

logic diagram (positive logic)

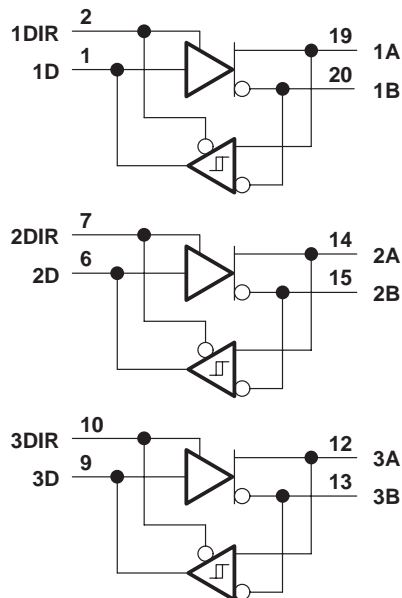

† This symbol is in accordance with ANSI/IEEE Std 91-1984 and IEC Publication 617-12.

Pin numbers shown are for the DW package.

schematics of inputs and outputs

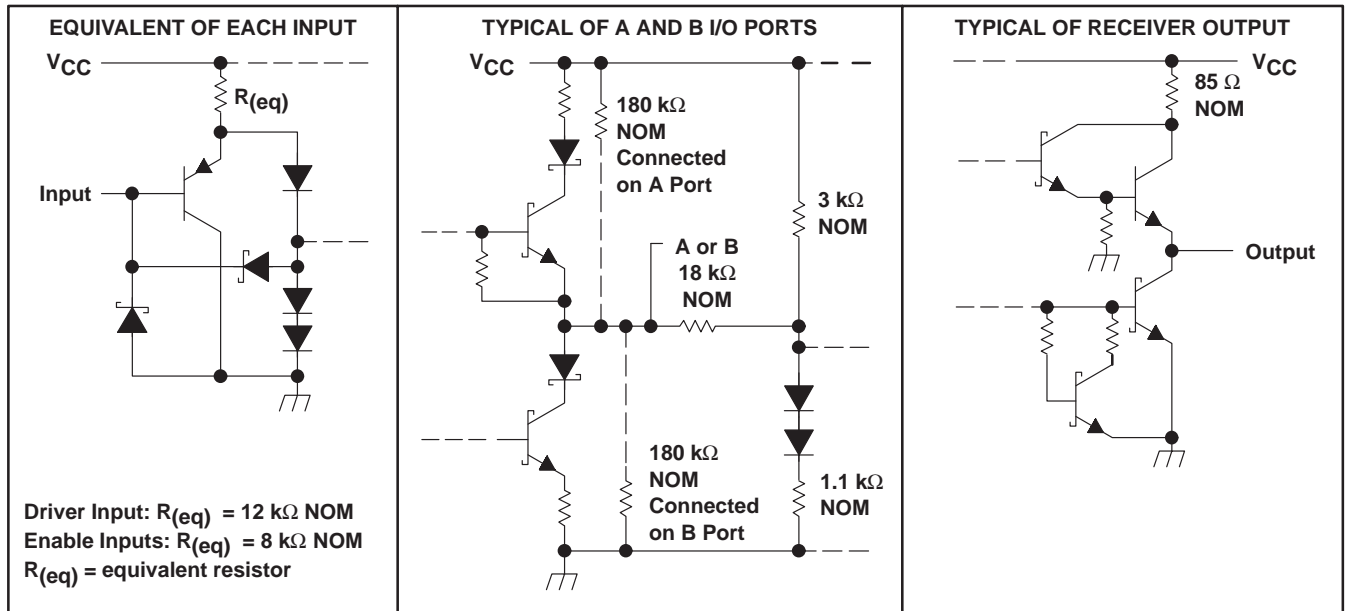

absolute maximum ratings over operating free-air temperature range (unless otherwise noted)†

Supply voltage, V_{CC} (see Note 1)	7 V
Voltage range at any bus terminal	-7 V to 12 V
Enable input voltage, V_I	5.5 V
Continuous total power dissipation	See Dissipation Rating Table
Operating free-air temperature range, T_A	0°C to 70°C
Storage temperature range, T_{stg}	-65°C to 150°C
Lead temperature 1,6 mm (1/16 inch) from case for 10 seconds: DW package	260°C
Lead temperature 1,6 mm (1/16 inch) from case for 60 seconds: J package	300°C

† Stresses beyond those listed under "absolute maximum ratings" may cause permanent damage to the device. These are stress ratings only, and functional operation of the device at these or any other conditions beyond those indicated under "recommended operating conditions" is not implied. Exposure to absolute-maximum-rated conditions for extended periods may affect device reliability.

NOTE 1: All voltage values, except differential I/O bus voltage, are with respect to network ground terminal.

DISSIPATION RATING TABLE

PACKAGE	$T_A \leq 25^\circ\text{C}$ POWER RATING	DERATING FACTOR ABOVE $T_A = 25^\circ\text{C}$	$T_A = 70^\circ\text{C}$ POWER RATING
DW	1125 mW	9.0 mW/°C	720 mW
J	1025 mW	8.2 mW/°C	656 mW

SN75ALS170, SN75ALS170A TRIPLE DIFFERENTIAL BUS TRANSCEIVER

SLLS055D – AUGUST 1987 – REVISED SEPTEMBER 1995

recommended operating conditions

		MIN	TYP	MAX	UNIT
Supply voltage, V_{CC}		4.75	5	5.25	V
Voltage at any bus terminal (separately or common mode), V_I or V_{IC}		12			V
		-7			
High-level input voltage, V_{IH}	D, DIR	2			V
Low-level input voltage, V_{IL}	D, DIR	0.8			V
Differential input voltage, V_{ID} (see Note 2)		± 12			V
High-level output current, I_{OH}	Driver	-60			mA
	Receiver	-400			μ A
Low-level output current, I_{OL}	Driver	60			mA
	Receiver	8			
Operating free-air temperature, T_A		0	70		$^{\circ}$ C

NOTE 2: Differential-input/output bus voltage is measured at the noninverting terminal A with respect to the inverting terminal B.



SN75ALS170, SN75ALS170A TRIPLE DIFFERENTIAL BUS TRANSCEIVER

SLLS055D – AUGUST 1987 – REVISED SEPTEMBER 1995

DRIVER SECTION

electrical characteristics over recommended ranges of supply voltage and operating free-air temperature (unless otherwise noted)

PARAMETER		TEST CONDITIONS†	MIN	TYP‡	MAX	UNIT
V_{IK}	Input clamp voltage	$I_I = -19 \text{ mA}$			-1.5	V
V_O	Output voltage	$I_O = 0$	0		6	V
V_{OH}	High-level output voltage	$V_{CC} = 4.75 \text{ V}$, $V_{IL} = 0.8 \text{ V}$, $V_{IH} = 2 \text{ V}$, $I_{OH} = -55 \text{ mA}$	2.7			V
V_{OL}	Low-level output voltage	$V_{CC} = 4.75 \text{ V}$, $V_{IL} = 0.8 \text{ V}$, $V_{IH} = 2 \text{ V}$, $I_{OL} = 55 \text{ mA}$			1.7	V
$ V_{OD1} $	Differential output voltage	$I_O = 0$	1.5		6	V
$ V_{OD2} $	Differential output voltage	$R_L = 100 \Omega$, See Figure 1	$1/2 V_{OD1}$ or 2§			V
		$R_L = 54 \Omega$, See Figure 1	1.5	2.5	5	V
V_{OD3}	Differential output voltage	$V_{\text{test}} = -7 \text{ V to } 12 \text{ V}$, See Figure 2	1.5		5	V
$\Delta V_{OD} $	Change in magnitude of differential output voltage¶				± 0.2	V
V_{OC}	Common-mode output voltage	$R_L = 540 \Omega$ or 100Ω , See Figure 1			3	V
					-1	V
$\Delta V_{OC} $	Change in magnitude of common-mode output voltage¶				± 0.2	V
I_O	Output current	Output disabled, See Note 3	$V_O = 12 \text{ V}$		1	mA
			$V_O = -7 \text{ V}$		-0.8	
I_{IH}	High-level input current	$V_I = 2.4 \text{ V}$			20	μA
I_{IL}	Low-level input current	$V_I = 0.4 \text{ V}$			-400	μA
I_{OS}	Short-circuit output current	$V_O = -6 \text{ V}$			-250	mA
		$V_O = 0$			-150	
		$V_O = V_{CC}$			250	
		$V_O = 8 \text{ V}$			250	
I_{CC}	Supply current	No load	Outputs enabled	69	90	mA
			Outputs disabled	57	78	

† The power-off measurement in ANSI Standard EIA/TIA-422-B applies to disabled outputs only and is not applied to combined inputs and outputs.

‡ All typical values are at $V_{CC} = 5 \text{ V}$ and $T_A = 25^\circ\text{C}$.

§ The minimum V_{OD2} with a $100\text{-}\Omega$ load is either $1/2 V_{OD1}$ or 2 V , whichever is greater.

¶ $\Delta |V_{OD}|$ and $\Delta |V_{OC}|$ are the changes in magnitude of V_{OD} and V_{OC} respectively, that occur when the input is changed from a high level to a low level.

NOTE 3: This applies for both power on and off; refer to EIA Standard RS-485 for exact conditions. The EIA/TIA-422-B limit does not apply for a combined driver and receiver terminal.

SN75ALS170, SN75ALS170A TRIPLE DIFFERENTIAL BUS TRANSCEIVER

SLLS055D – AUGUST 1987 – REVISED SEPTEMBER 1995

switching characteristics over recommended ranges of supply voltage and operating free-air temperature (unless otherwise noted)

PARAMETER		TEST CONDITIONS		MIN	TYP†	MAX	UNIT	
$t_{d(OD)}$	Differential output delay time	ALS170	$R_L = 54 \Omega$, $T_A = 25^\circ\text{C}$,	$C_L = 50 \text{ pF}$, See Figure 3	3	8	13	ns
		ALS170A			5.5	8	10.5	
		ALS170	$R_{L1} = R_{L3} = 165 \Omega$, $C_L = 60 \text{ pF}$, See Figure 4	$R_{L2} = 75 \Omega$, $T_A = 25^\circ\text{C}$,	3	8	13	
		ALS170A			5.5	8	10.5	
$t_{sk(p)}$	Pulse skew‡	$R_L = 54 \Omega$, See Figure 3		$C_L = 50 \text{ pF}$,	1	5	ns	
		$R_{L1} = R_{L3} = 165 \Omega$, $C_L = 60 \text{ pF}$,		$R_{L2} = 75 \Omega$, See Figure 4	1	5	ns	
$t_{sk(lim)}$	Skew limit§	ALS170	$R_L = 54 \Omega$, See Figure 3	$C_L = 50 \text{ pF}$,			10	ns
		ALS170A					5	
		ALS170	$R_{L1} = R_{L3} = 165 \Omega$, $C_L = 60 \text{ pF}$,	$R_{L2} = 75 \Omega$, See Figure 4			10	
		ALS170A					5	
$t_t(OD)$	Differential-output transition time	$R_L = 54 \Omega$, See Figure 3		$C_L = 50 \text{ pF}$,	3	8	13	ns
		$R_{L1} = R_{L3} = 165 \Omega$, $C_L = 60 \text{ pF}$,		$R_{L2} = 75 \Omega$, See Figure 4	3	8	13	

† All typical values are at $V_{CC} = 5 \text{ V}$ and $T_A = 25^\circ\text{C}$.

‡ Pulse skew is defined as the $|t_{d(ODH)} - t_{d(ODL)}|$ of each channel.

§ Skew limit is the maximum difference in propagation delay times between any two channels of one device and between any two devices. This parameter is applicable at one V_{CC} and operating temperature within the recommended operating conditions.

SYMBOL EQUIVALENTS

DATA SHEET PARAMETER	EIA/TIA-422-B	RS-485
V_O	V_{Oa}, V_{Ob}	V_{Oa}, V_{Ob}
$ V_{OD1} $	V_O	V_O
$ V_{OD2} $	$V_t (R_L = 100 \Omega)$	$V_t (R_L = 54 \Omega)$
$ V_{OD3} $		V_t (Test Termination Measurement 2)
V_{test}		V_{tst}
$\Delta V_{OD} $	$ V_t - \bar{V}_t $	$ V_t - \bar{V}_t $
V_{OC}	$ V_{os} $	$ V_{os} $
$\Delta V_{OC} $	$ V_{os} - \bar{V}_{os} $	$ V_{os} - \bar{V}_{os} $
I_{OS}	$ I_{sa} , I_{sb} $	
I_O	$ I_{xa} , I_{xb} $	I_{ia}, I_{ib}



SN75ALS170, SN75ALS170A TRIPLE DIFFERENTIAL BUS TRANSCEIVER

SLLS055D – AUGUST 1987 – REVISED SEPTEMBER 1995

RECEIVER SECTION

electrical characteristics over recommended ranges of common-mode input voltage, supply voltage, and operating free-air temperature (unless otherwise noted)

PARAMETER		TEST CONDITIONS		MIN	TYP†	MAX	UNIT
V_{IT+}	Positive-going input threshold voltage	$V_O = 2.7\text{ V}$,	$I_O = -0.4\text{ mA}$			0.3	V
V_{IT-}	Negative-going input threshold voltage	$V_O = 0.5\text{ V}$,	$I_O = 8\text{ mA}$	-0.3‡			V
V_{hys}	Hysteresis voltage ($V_{IT+} - V_{IT-}$)				60		mV
V_{IK}	Enable-input clamp voltage	$I_I = -18\text{ mA}$				-1.5	V
V_{OH}	High-level output voltage	$V_{ID} = 300\text{ mV}$, See Figure 5	$I_{OH} = -400\text{ }\mu\text{A}$,		2.7		V
V_{OL}	Low-level output voltage	$V_{ID} = -300\text{ mV}$, See Figure 5	$I_{OL} = 8\text{ mA}$,			0.45	V
I_{OZ}	High-impedance-state output current	$V_O = 2.4\text{ V}$				20	μA
		$V_O = 0.4\text{ V}$				-400	
I_I	Line input current	Other input = 0, See Note 4	$V_I = 12\text{ V}$			1	mA
			$V_I = -7\text{ V}$			-0.8	
I_{IH}	High-level enable-input current	$V_{IH} = 2.7\text{ V}$				20	μA
I_{IL}	Low-level enable-input current	$V_{IL} = 0.4\text{ V}$				-100	μA
r_I	Input resistance				12		k Ω
I_{OS}	Short-circuit output current	$V_{ID} = 300\text{ mV}$,	$V_O = 0$	-15		-85	mA
I_{CC}	Supply current	No load	Outputs enabled		69	90	mA
			Outputs disabled		57	78	

† All typical values are at $V_{CC} = 5\text{ V}$ and $T_A = 25^\circ\text{C}$.

‡ The algebraic convention, in which the less-positive (more-negative) limit is designated minimum, is used in this data sheet for common-mode input voltage and threshold voltage levels only.

NOTE 4: This applies for both power on and off; refer to EIA Standard RS-485 for exact conditions.

switching characteristics over recommended ranges of supply voltage and operating free-air temperature range

PARAMETER		TEST CONDITIONS		MIN	TYP†	MAX	UNIT	
t_{PLH}	Propagation delay time, low-to-high-level output	ALS170	$V_{ID} = -1.5\text{ V to }1.5\text{ V}$, $C_L = 15\text{ pF}$, $T_A = 25^\circ\text{C}$, See Figure 6	9		19	ns	
		ALS170A		11.5		16.5		
t_{PHL}	Propagation delay time, high-to-low-level output	ALS170		9		19	ns	
		ALS170A		11.5		16.5		
$t_{sk(p)}$	Pulse skew§	ALS170	$V_{ID} = -1.5\text{ V to }1.5\text{ V}$, $C_L = 15\text{ pF}$, See Figure 6		2	6	ns	
		ALS170A				5		
$t_{sk(lim)}$	Skew limit¶	ALS170					10	ns
		ALS170A					5	

† All typical values are at $V_{CC} = 5\text{ V}$ and $T_A = 25^\circ\text{C}$.

§ Pulse skew is defined as the $|t_{PLH} - t_{PHL}|$ of each channel.

¶ Skew limit is the maximum difference in propagation delay times between any two channels of one device and between any two devices. This parameter is applicable at one V_{CC} and operating temperature within the recommended operating conditions.



SN75ALS170, SN75ALS170A TRIPLE DIFFERENTIAL BUS TRANSCEIVER

SLLS055D – AUGUST 1987 – REVISED SEPTEMBER 1995

PARAMETER MEASUREMENT INFORMATION

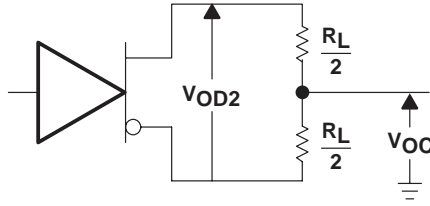

Figure 1. Driver V_{OD} and V_{OC}

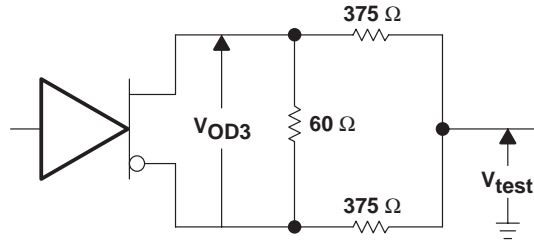
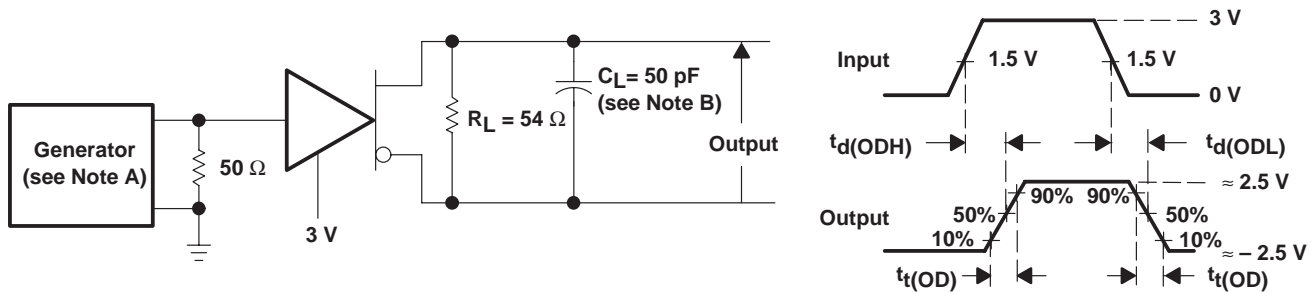

Figure 2. Driver V_{OD3}



TEST CIRCUIT

VOLTAGE WAVEFORMS

- NOTES: A. The input pulse is supplied by a generator having the following characteristics: $PRR \leq 1 \text{ MHz}$, 50% duty cycle, $t_r \leq 6 \text{ ns}$, $t_f \leq 6 \text{ ns}$, $Z_O = 50 \Omega$.
 B. C_L includes probe and jig capacitance.

Figure 3. Driver Test Circuit and Voltage Waveforms

PARAMETER MEASUREMENT INFORMATION

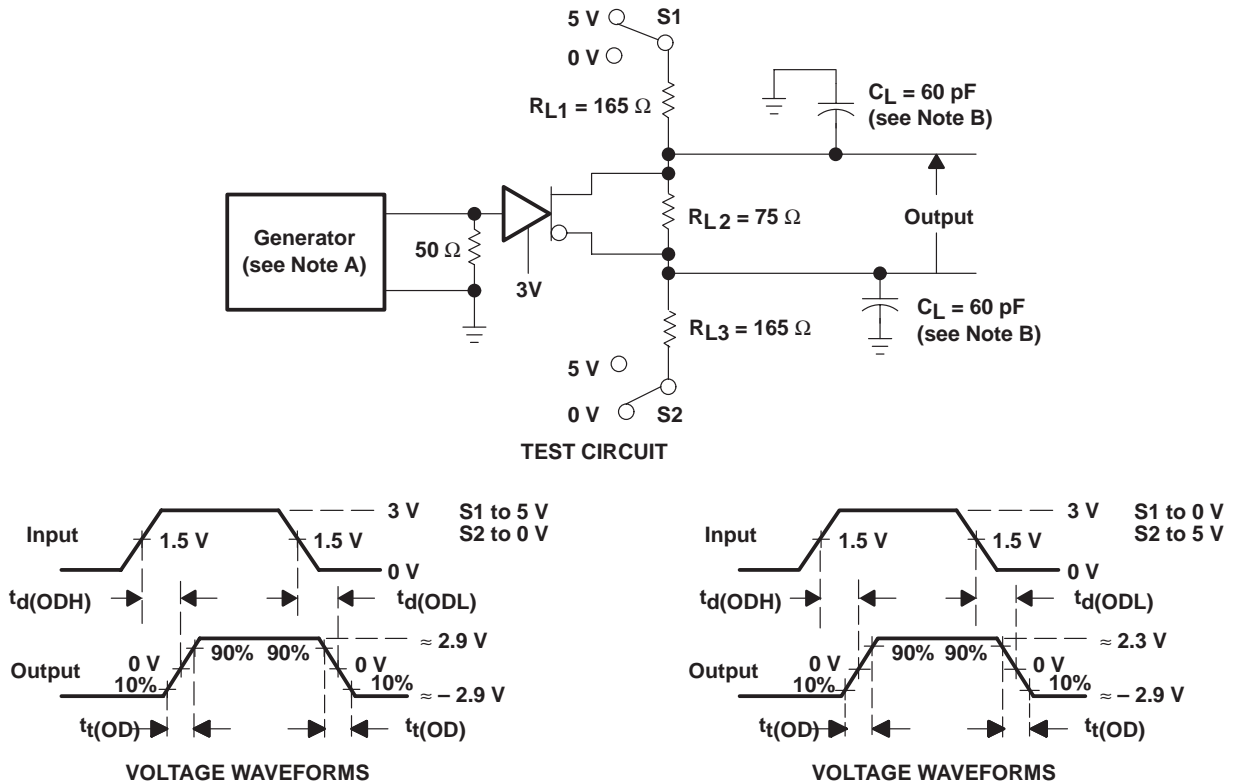

- NOTES: A. The input pulse is supplied by a generator having the following characteristics: PRR \leq 1 MHz, 50% duty cycle, $t_r \leq$ 6 ns, $t_f \leq$ 6 ns, $Z_0 = 50 \Omega$.
B. C_L includes probe and jig capacitance.

Figure 4. Driver Test Circuit and Voltage Waveforms With Double-Differential-SCSI Termination for the Load

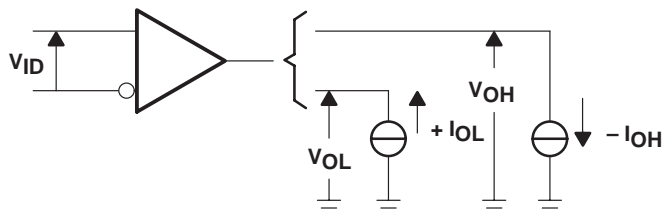
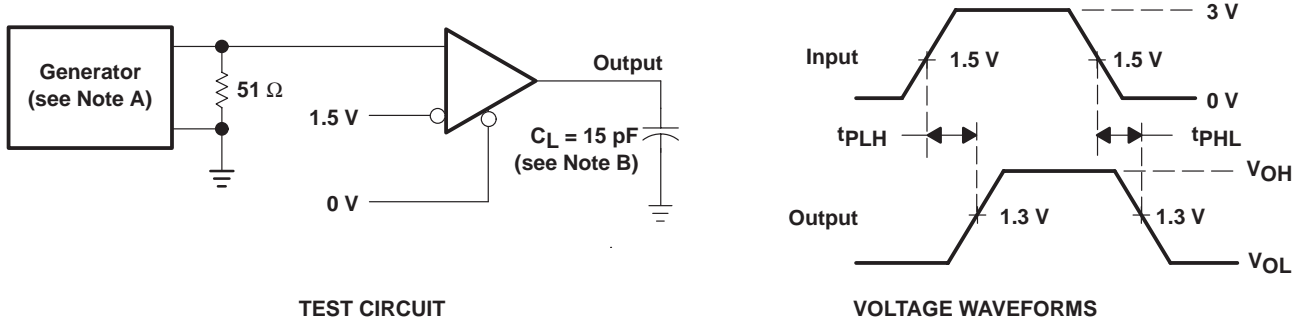

Figure 5. Receiver V_{OH} and V_{OL}

SN75ALS170, SN75ALS170A TRIPLE DIFFERENTIAL BUS TRANSCEIVER

SLLS055D – AUGUST 1987 – REVISED SEPTEMBER 1995

PARAMETER MEASUREMENT INFORMATION



- NOTES: A. The input pulse is supplied by a generator having the following characteristics: $PRR \leq 1 \text{ MHz}$, 50% duty cycle, $t_r \leq 6 \text{ ns}$, $t_f \leq 6 \text{ ns}$, $Z_O = 50 \Omega$.
 B. C_L includes probe and jig capacitance.

Figure 6. Receiver Test Circuit and Voltage Waveforms

TYPICAL CHARACTERISTICS

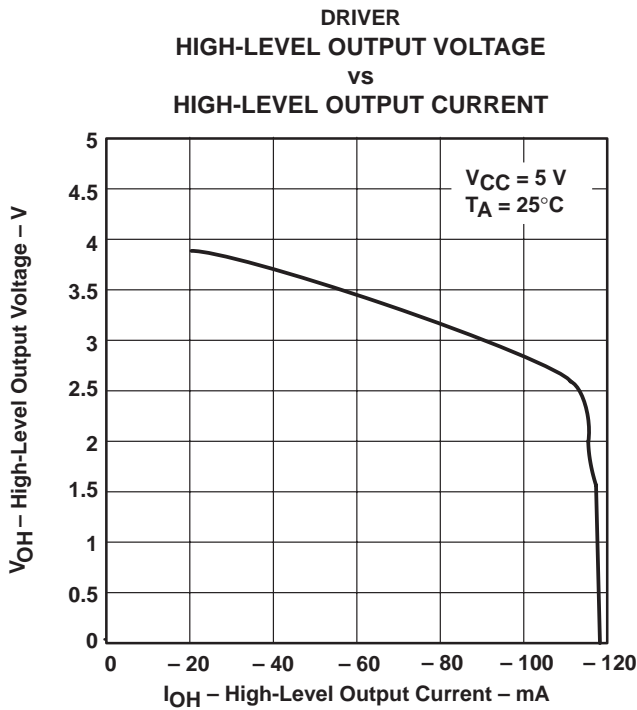

Figure 7

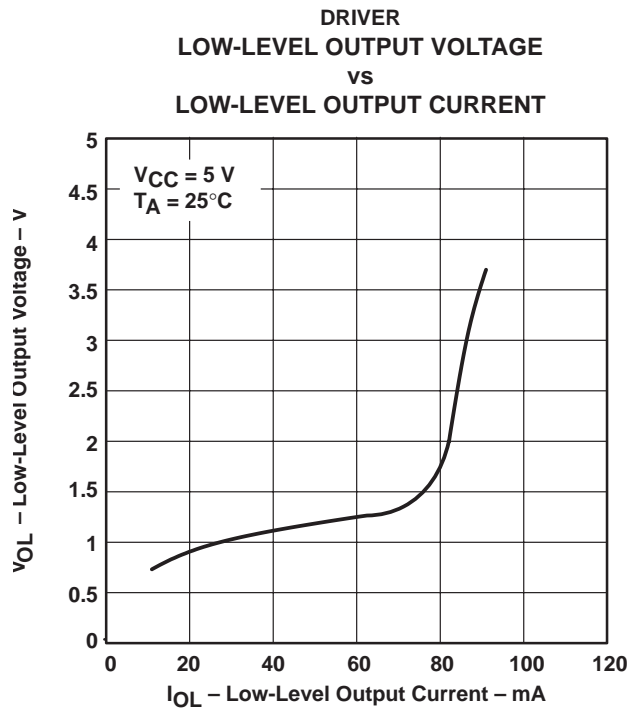

Figure 8

TYPICAL CHARACTERISTICS

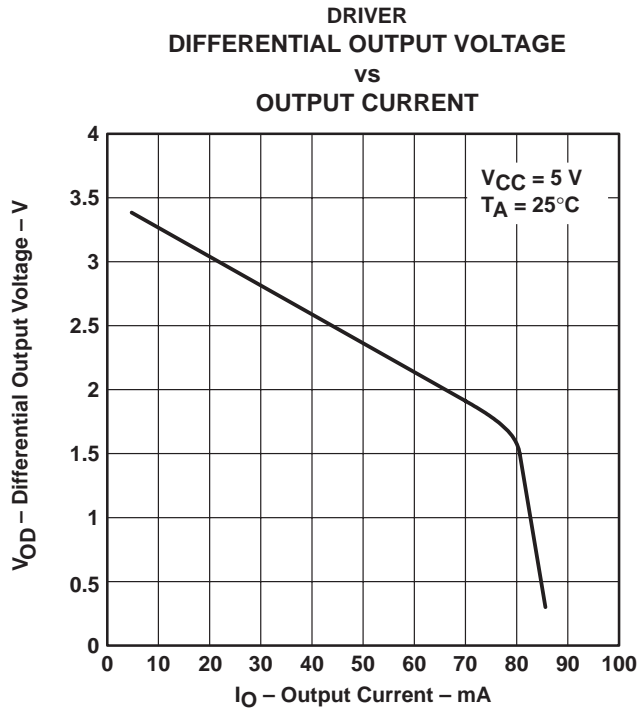

Figure 9

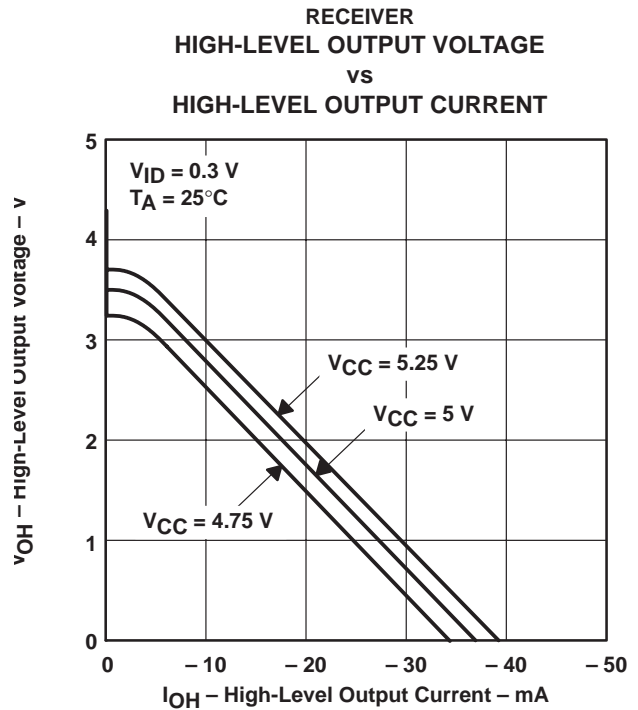

Figure 10

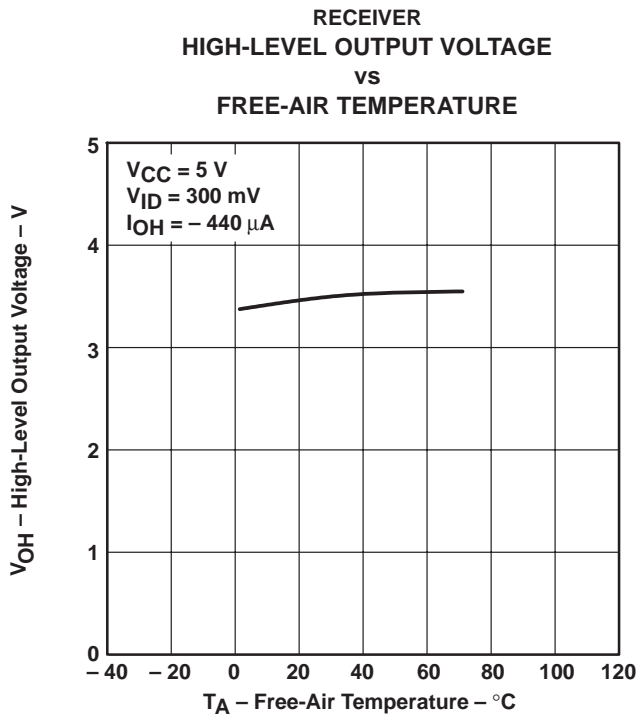

Figure 11

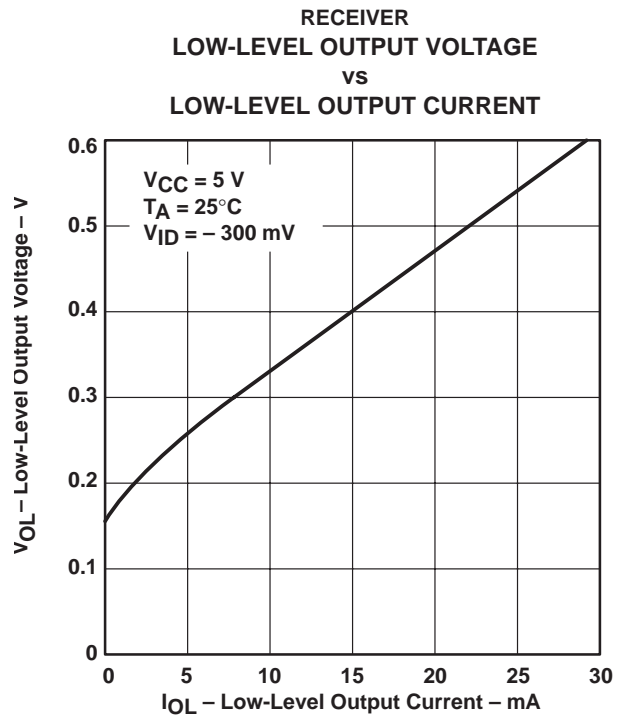

Figure 12

SN75ALS170, SN75ALS170A TRIPLE DIFFERENTIAL BUS TRANSCEIVER

SLLS055D – AUGUST 1987 – REVISED SEPTEMBER 1995

TYPICAL CHARACTERISTICS

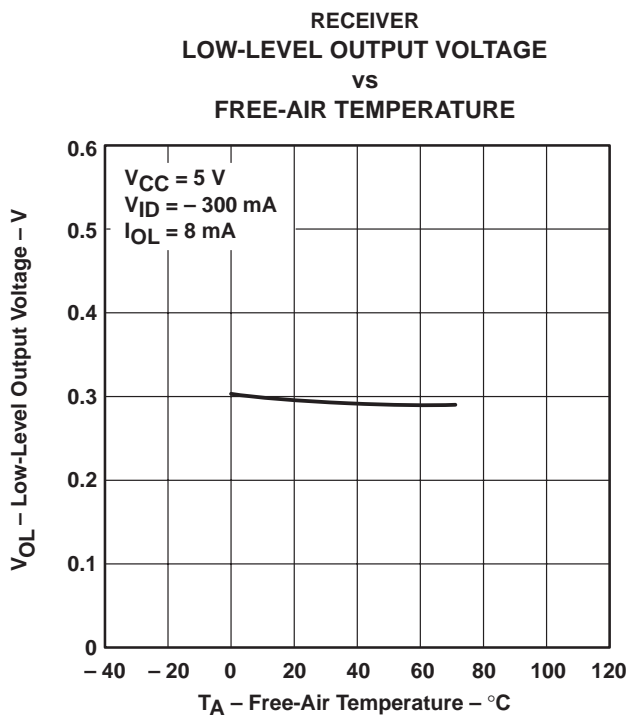

Figure 13

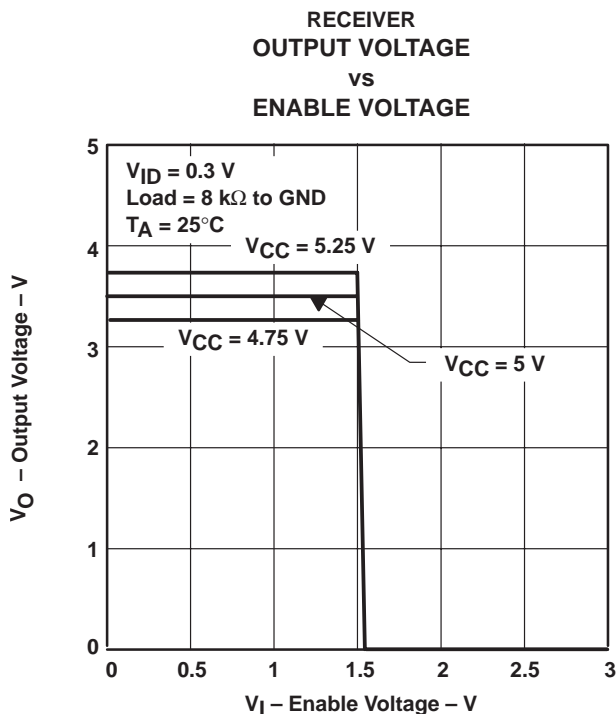

Figure 14

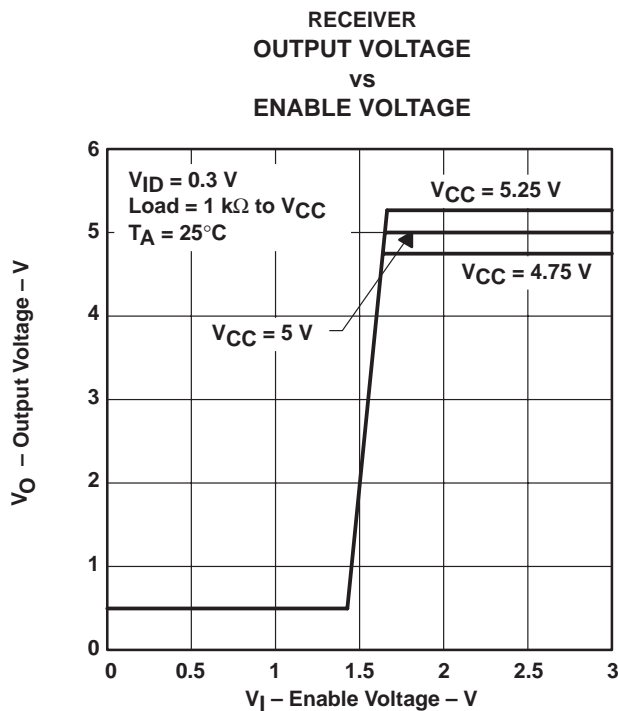
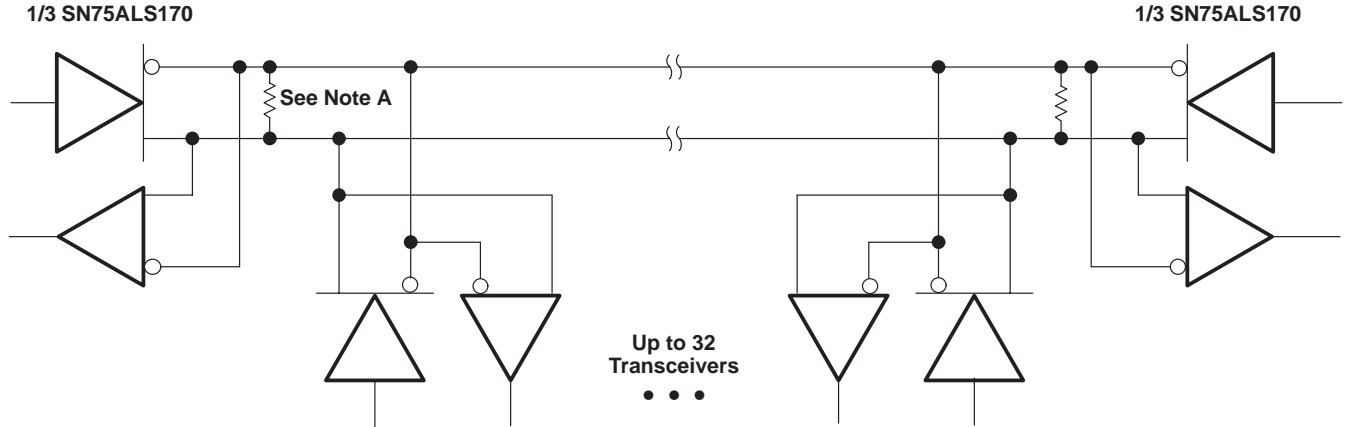

Figure 15



APPLICATION INFORMATION



NOTE A: The line should be terminated at both ends in its characteristic impedance. Stub lengths off the main line should be kept as short as possible.

Figure 16. Typical Application Circuit

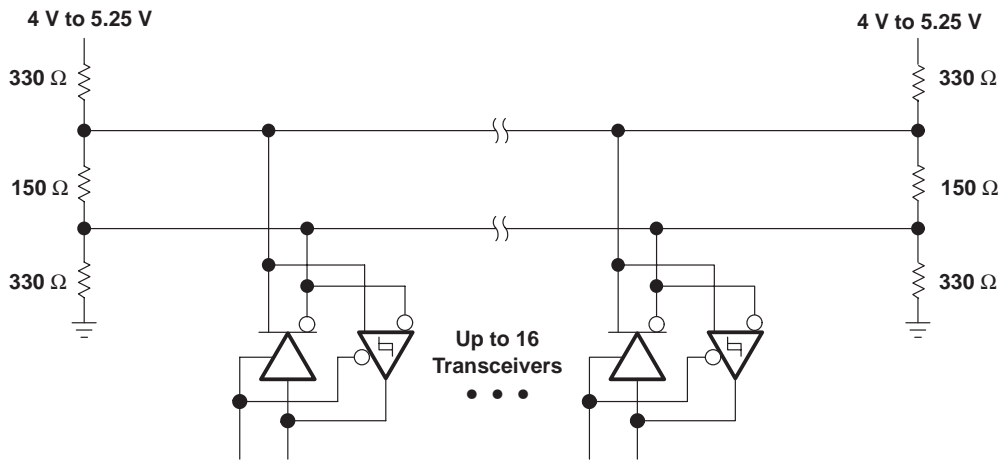

Figure 17. Typical Differential SCSI Application Circuit

SN75ALS170, SN75ALS170A TRIPLE DIFFERENTIAL BUS TRANSCEIVER

SLLS055D – AUGUST 1987 – REVISED SEPTEMBER 1995

APPLICATION INFORMATION

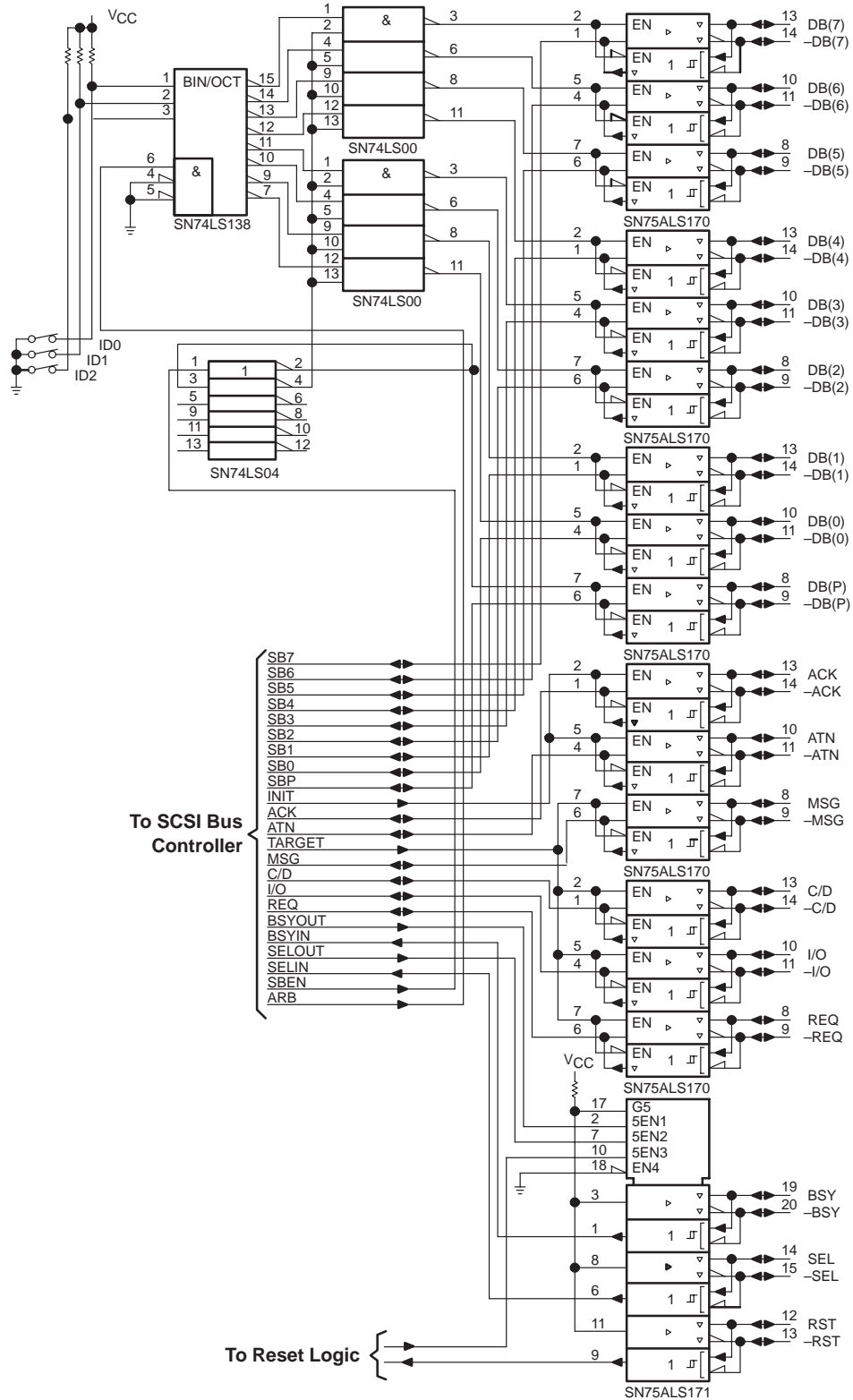

Figure 18. Typical Differential SCSI Bus Interface Implementation



PACKAGING INFORMATION

Orderable Device	Status (1)	Package Type	Package Drawing	Pins	Package Qty	Eco Plan (2)	Lead/Ball Finish (6)	MSL Peak Temp (3)	Op Temp (°C)	Device Marking (4/5)	Samples
SN75ALS170ADW	ACTIVE	SOIC	DW	20	25	Green (RoHS & no Sb/Br)	CU NIPDAU	Level-1-260C-UNLIM	0 to 70	75ALS170A	Samples
SN75ALS170ADWR	ACTIVE	SOIC	DW	20	2000	Green (RoHS & no Sb/Br)	CU NIPDAU	Level-1-260C-UNLIM	0 to 70	75ALS170A	Samples
SN75ALS170DW	ACTIVE	SOIC	DW	20	25	Green (RoHS & no Sb/Br)	CU NIPDAU	Level-1-260C-UNLIM	0 to 70	75ALS170	Samples
SN75ALS170DWG4	ACTIVE	SOIC	DW	20	25	Green (RoHS & no Sb/Br)	CU NIPDAU	Level-1-260C-UNLIM	0 to 70	75ALS170	Samples
SN75ALS170DWR	ACTIVE	SOIC	DW	20	2000	Green (RoHS & no Sb/Br)	CU NIPDAU	Level-1-260C-UNLIM	0 to 70	75ALS170	Samples
SN75ALS170DWRG4	ACTIVE	SOIC	DW	20	2000	Green (RoHS & no Sb/Br)	CU NIPDAU	Level-1-260C-UNLIM	0 to 70	75ALS170	Samples

(1) The marketing status values are defined as follows:

ACTIVE: Product device recommended for new designs.

LIFEBUY: TI has announced that the device will be discontinued, and a lifetime-buy period is in effect.

NRND: Not recommended for new designs. Device is in production to support existing customers, but TI does not recommend using this part in a new design.

PREVIEW: Device has been announced but is not in production. Samples may or may not be available.

OBSELETE: TI has discontinued the production of the device.

(2) Eco Plan - The planned eco-friendly classification: Pb-Free (RoHS), Pb-Free (RoHS Exempt), or Green (RoHS & no Sb/Br) - please check <http://www.ti.com/productcontent> for the latest availability information and additional product content details.

TBD: The Pb-Free/Green conversion plan has not been defined.

Pb-Free (RoHS): TI's terms "Lead-Free" or "Pb-Free" mean semiconductor products that are compatible with the current RoHS requirements for all 6 substances, including the requirement that lead not exceed 0.1% by weight in homogeneous materials. Where designed to be soldered at high temperatures, TI Pb-Free products are suitable for use in specified lead-free processes.

Pb-Free (RoHS Exempt): This component has a RoHS exemption for either 1) lead-based flip-chip solder bumps used between the die and package, or 2) lead-based die adhesive used between the die and leadframe. The component is otherwise considered Pb-Free (RoHS compatible) as defined above.

Green (RoHS & no Sb/Br): TI defines "Green" to mean Pb-Free (RoHS compatible), and free of Bromine (Br) and Antimony (Sb) based flame retardants (Br or Sb do not exceed 0.1% by weight in homogeneous material)

(3) MSL, Peak Temp. - The Moisture Sensitivity Level rating according to the JEDEC industry standard classifications, and peak solder temperature.

(4) There may be additional marking, which relates to the logo, the lot trace code information, or the environmental category on the device.

(5) Multiple Device Markings will be inside parentheses. Only one Device Marking contained in parentheses and separated by a "~" will appear on a device. If a line is indented then it is a continuation of the previous line and the two combined represent the entire Device Marking for that device.

⁽⁶⁾ Lead/Ball Finish - Orderable Devices may have multiple material finish options. Finish options are separated by a vertical ruled line. Lead/Ball Finish values may wrap to two lines if the finish value exceeds the maximum column width.

Important Information and Disclaimer: The information provided on this page represents TI's knowledge and belief as of the date that it is provided. TI bases its knowledge and belief on information provided by third parties, and makes no representation or warranty as to the accuracy of such information. Efforts are underway to better integrate information from third parties. TI has taken and continues to take reasonable steps to provide representative and accurate information but may not have conducted destructive testing or chemical analysis on incoming materials and chemicals. TI and TI suppliers consider certain information to be proprietary, and thus CAS numbers and other limited information may not be available for release.

In no event shall TI's liability arising out of such information exceed the total purchase price of the TI part(s) at issue in this document sold by TI to Customer on an annual basis.

TAPE AND REEL INFORMATION



QUADRANT ASSIGNMENTS FOR PIN 1 ORIENTATION IN TAPE



*All dimensions are nominal

Device	Package Type	Package Drawing	Pins	SPQ	Reel Diameter (mm)	Reel Width W1 (mm)	A0 (mm)	B0 (mm)	K0 (mm)	P1 (mm)	W (mm)	Pin1 Quadrant
SN75ALS170ADWR	SOIC	DW	20	2000	330.0	24.4	10.8	13.3	2.7	12.0	24.0	Q1
SN75ALS170DWR	SOIC	DW	20	2000	330.0	24.4	10.8	13.3	2.7	12.0	24.0	Q1

TAPE AND REEL BOX DIMENSIONS

*All dimensions are nominal

Device	Package Type	Package Drawing	Pins	SPQ	Length (mm)	Width (mm)	Height (mm)
SN75ALS170ADWR	SOIC	DW	20	2000	367.0	367.0	45.0
SN75ALS170DWR	SOIC	DW	20	2000	367.0	367.0	45.0

DW0020A



PACKAGE OUTLINE

SOIC - 2.65 mm max height

SOIC



4220724/A 05/2016

NOTES:

1. All linear dimensions are in millimeters. Dimensions in parenthesis are for reference only. Dimensioning and tolerancing per ASME Y14.5M.
2. This drawing is subject to change without notice.
3. This dimension does not include mold flash, protrusions, or gate burrs. Mold flash, protrusions, or gate burrs shall not exceed 0.15 mm per side.
4. This dimension does not include interlead flash. Interlead flash shall not exceed 0.43 mm per side.
5. Reference JEDEC registration MS-013.

EXAMPLE BOARD LAYOUT

DW0020A

SOIC - 2.65 mm max height

SOIC



LAND PATTERN EXAMPLE
SCALE:6X



SOLDER MASK DETAILS

4220724/A 05/2016

NOTES: (continued)

- 6. Publication IPC-7351 may have alternate designs.
- 7. Solder mask tolerances between and around signal pads can vary based on board fabrication site.

EXAMPLE STENCIL DESIGN

DW0020A

SOIC - 2.65 mm max height

SOIC



SOLDER PASTE EXAMPLE
BASED ON 0.125 mm THICK STENCIL
SCALE:6X

4220724/A 05/2016

NOTES: (continued)

8. Laser cutting apertures with trapezoidal walls and rounded corners may offer better paste release. IPC-7525 may have alternate design recommendations.
9. Board assembly site may have different recommendations for stencil design.

IMPORTANT NOTICE

Texas Instruments Incorporated (TI) reserves the right to make corrections, enhancements, improvements and other changes to its semiconductor products and services per JESD46, latest issue, and to discontinue any product or service per JESD48, latest issue. Buyers should obtain the latest relevant information before placing orders and should verify that such information is current and complete.

TI's published terms of sale for semiconductor products (<http://www.ti.com/sc/docs/stdterms.htm>) apply to the sale of packaged integrated circuit products that TI has qualified and released to market. Additional terms may apply to the use or sale of other types of TI products and services.

Reproduction of significant portions of TI information in TI data sheets is permissible only if reproduction is without alteration and is accompanied by all associated warranties, conditions, limitations, and notices. TI is not responsible or liable for such reproduced documentation. Information of third parties may be subject to additional restrictions. Resale of TI products or services with statements different from or beyond the parameters stated by TI for that product or service voids all express and any implied warranties for the associated TI product or service and is an unfair and deceptive business practice. TI is not responsible or liable for any such statements.

Buyers and others who are developing systems that incorporate TI products (collectively, "Designers") understand and agree that Designers remain responsible for using their independent analysis, evaluation and judgment in designing their applications and that Designers have full and exclusive responsibility to assure the safety of Designers' applications and compliance of their applications (and of all TI products used in or for Designers' applications) with all applicable regulations, laws and other applicable requirements. Designer represents that, with respect to their applications, Designer has all the necessary expertise to create and implement safeguards that (1) anticipate dangerous consequences of failures, (2) monitor failures and their consequences, and (3) lessen the likelihood of failures that might cause harm and take appropriate actions. Designer agrees that prior to using or distributing any applications that include TI products, Designer will thoroughly test such applications and the functionality of such TI products as used in such applications.

TI's provision of technical, application or other design advice, quality characterization, reliability data or other services or information, including, but not limited to, reference designs and materials relating to evaluation modules, (collectively, "TI Resources") are intended to assist designers who are developing applications that incorporate TI products; by downloading, accessing or using TI Resources in any way, Designer (individually or, if Designer is acting on behalf of a company, Designer's company) agrees to use any particular TI Resource solely for this purpose and subject to the terms of this Notice.

TI's provision of TI Resources does not expand or otherwise alter TI's applicable published warranties or warranty disclaimers for TI products, and no additional obligations or liabilities arise from TI providing such TI Resources. TI reserves the right to make corrections, enhancements, improvements and other changes to its TI Resources. TI has not conducted any testing other than that specifically described in the published documentation for a particular TI Resource.

Designer is authorized to use, copy and modify any individual TI Resource only in connection with the development of applications that include the TI product(s) identified in such TI Resource. NO OTHER LICENSE, EXPRESS OR IMPLIED, BY ESTOPPEL OR OTHERWISE TO ANY OTHER TI INTELLECTUAL PROPERTY RIGHT, AND NO LICENSE TO ANY TECHNOLOGY OR INTELLECTUAL PROPERTY RIGHT OF TI OR ANY THIRD PARTY IS GRANTED HEREIN, including but not limited to any patent right, copyright, mask work right, or other intellectual property right relating to any combination, machine, or process in which TI products or services are used. Information regarding or referencing third-party products or services does not constitute a license to use such products or services, or a warranty or endorsement thereof. Use of TI Resources may require a license from a third party under the patents or other intellectual property of the third party, or a license from TI under the patents or other intellectual property of TI.

TI RESOURCES ARE PROVIDED "AS IS" AND WITH ALL FAULTS. TI DISCLAIMS ALL OTHER WARRANTIES OR REPRESENTATIONS, EXPRESS OR IMPLIED, REGARDING RESOURCES OR USE THEREOF, INCLUDING BUT NOT LIMITED TO ACCURACY OR COMPLETENESS, TITLE, ANY EPIDEMIC FAILURE WARRANTY AND ANY IMPLIED WARRANTIES OF MERCHANTABILITY, FITNESS FOR A PARTICULAR PURPOSE, AND NON-INFRINGEMENT OF ANY THIRD PARTY INTELLECTUAL PROPERTY RIGHTS. TI SHALL NOT BE LIABLE FOR AND SHALL NOT DEFEND OR INDEMNIFY DESIGNER AGAINST ANY CLAIM, INCLUDING BUT NOT LIMITED TO ANY INFRINGEMENT CLAIM THAT RELATES TO OR IS BASED ON ANY COMBINATION OF PRODUCTS EVEN IF DESCRIBED IN TI RESOURCES OR OTHERWISE. IN NO EVENT SHALL TI BE LIABLE FOR ANY ACTUAL, DIRECT, SPECIAL, COLLATERAL, INDIRECT, PUNITIVE, INCIDENTAL, CONSEQUENTIAL OR EXEMPLARY DAMAGES IN CONNECTION WITH OR ARISING OUT OF TI RESOURCES OR USE THEREOF, AND REGARDLESS OF WHETHER TI HAS BEEN ADVISED OF THE POSSIBILITY OF SUCH DAMAGES.

Unless TI has explicitly designated an individual product as meeting the requirements of a particular industry standard (e.g., ISO/TS 16949 and ISO 26262), TI is not responsible for any failure to meet such industry standard requirements.

Where TI specifically promotes products as facilitating functional safety or as compliant with industry functional safety standards, such products are intended to help enable customers to design and create their own applications that meet applicable functional safety standards and requirements. Using products in an application does not by itself establish any safety features in the application. Designers must ensure compliance with safety-related requirements and standards applicable to their applications. Designer may not use any TI products in life-critical medical equipment unless authorized officers of the parties have executed a special contract specifically governing such use. Life-critical medical equipment is medical equipment where failure of such equipment would cause serious bodily injury or death (e.g., life support, pacemakers, defibrillators, heart pumps, neurostimulators, and implantables). Such equipment includes, without limitation, all medical devices identified by the U.S. Food and Drug Administration as Class III devices and equivalent classifications outside the U.S.

TI may expressly designate certain products as completing a particular qualification (e.g., Q100, Military Grade, or Enhanced Product). Designers agree that it has the necessary expertise to select the product with the appropriate qualification designation for their applications and that proper product selection is at Designers' own risk. Designers are solely responsible for compliance with all legal and regulatory requirements in connection with such selection.

Designer will fully indemnify TI and its representatives against any damages, costs, losses, and/or liabilities arising out of Designer's non-compliance with the terms and provisions of this Notice.